

GENERAL INSTRUCTION SAFETY DIRECTIVES

INSTALLATION INSTRUCTION



SAFETY DIRECTIVES

Using the air handling unit	2
Free space for service and repair work	2

GENERAL INSTRUCTION

Checking prior to commissioning	3
Dismantling/Reassembly.....	3
Sound transmission.....	3
Lifting and transport	4
Lifting a unit provided with lifting device EQAZ-02.....	4
Lifting a unit provided with a base frame EQAZ-04	5
Lifting and transport, outdoor version	5
EQAZ-04 Base frame, Unit sizes 005-090	6
Assemblage of the EQAZ-04 in separately delivered version.....	6
To fit (secure) the unit to the base frame	6
Mounting on the floor	7
Mounting on the foundation, outdoor version, unit sizes 009-090.....	8
Jointing of air handling unit blocks.....	9

Suspended mounting from the ceiling	12
Heavy duty installation	12
Suspended installation, hygienic version, unit sizes 005-090	13
Unit stacked on top of one another (only for EQGA, EQGB).....	14
Supporting frame for overhanging unit parts	15
Vertical mounting. The unit must be ordered for vertical installation. Unit sizes 005-032 (single deck casing), 005-008 (double deck casing).....	16
Mounting on a wall stand	16
Mounting on a floor stand	16
Installation of the joints, only applies for outdoor units	17
To dismantle the handles with/without lock	18
To adjust the hinges	18
Connection to the ducting	19
Installation principle – Duct fitted to fan outlet	19
Maintenance.....	19
Replacement of door seal	19
Spare parts	19
Inspection intervals.....	19

SAFETY DIRECTIVES

USING THE AIR HANDLING UNIT



CAUTION!

Before the air handling unit is taken into operation, all unprotected openings must be equipped with protective screens.



The air handling unit must not be taken into operation before all electrical and mechanical safety devices have been installed.

Take great care when opening the air purging connections for the hot water supplied to the air heater. Bear in mind the risk of water hammer or steam discharge.

Whenever service work or inspection is to be carried out, all safety isolating switches of the unit should be tripped 1 minute before the inspection doors are opened. Before restarting, all safety devices must be restored.

If the eQ air handling unit is disassembled prior to installation, FläktGroup declines any responsibility for conformance of the unit to its rated tightness class.

The air handling unit covers are equipped with lockable handles. Be sure that you always leave the unit with the covers locked and keep the keys inaccessible to unauthorized persons.

Follow separate instruction for replacement of components.

There should be a service aisle in front of the electrical cabinet, this is to be arranged so that the cabinet can be serviced safely in accordance with local electrical safety regulations.

Planning for work of this type is a condition that must be complied with in order for the air handling unit to be CE marked. Local provisions and regulations shall be observed.

Read and understand these instructions before you begin installing the air handling unit. The owner or the fitter of the air handling unit is responsible for seeing to it that the safety regulations in force are followed.

No unauthorized person shall be allowed to work with the air handling unit. Only qualified personnel.

FREE SPACE FOR SERVICE AND REPAIR WORK

The space around the air handling unit shall be planned for routine service work such as filter replacement and cleaning fans and fan casings. Consideration must also be given to future replacement of components such as filter, heat exchangers, air heaters, air coolers, control box and fans.

Unit viewed from above

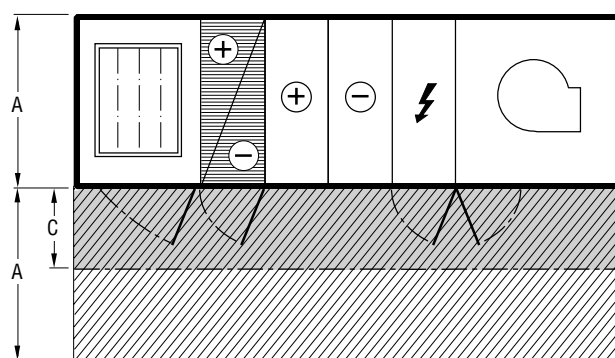

A = width for replacing components

C = width for replacing filter

Size	A	C
005	800	600
008	1100	800
009	800	600
011	1200	500
014	1100	600
018	1400	600
020	1100	600
023	1700	600
027	1400	600
032	1800	400
036	1400	600
041	2000	600

Size	A	C
045	1700	600
050	2300	500
054	2000	600
056	1700	600
063	2300	600
068	2000	600
072	2600	600
079	2300	600
090	2600	600

GENERAL INSTRUCTION

CHECKING PRIOR TO COMMISSIONING

1. Work through the following points depending on whether the components are present in the unit concerned. Start with the electrical connection switched off.
 - 2a. Check that the unit is aligned horizontally.
 - 2b. Check that the inspection doors operate easily. If necessary, adjust the hinges according to the separate instruction.
3. Check that the unit is clean internally and externally.
- 4a. Damper with actuator.
Check that the outdoor air and exhaust air dampers are closed when the actuating motor is in its end position, and that it opens the damper on starting the fan. The return air dampers shall be open in the corresponding position.
- 4b. Damper with manual adjustment.
The damper shall be locked in the open position before starting the fan.



N.B.!

The fan must never be started with the dampers closed.

5. Filter.
Check that the filter cassettes are in place, and that the locking device is closed.
 - For all air handling units placed on the European market after 1st January 2018 the EU regulation 1253/2014 states that they must be equipped with a visual signal or signal to the control system for filter change. All AHU:s with FläktGroup integrated controls is equipped with alarm or monitoring of filter pressure drop. For units without FläktGroup AHU controller this must be arranged by the installer.
6. Manometers and flow instruments.
Check that the instruments are zeroed and correctly connected (+/-) to the measurement socket.
7. Filter sensor.
Set the desired pressure difference on the filter sensor, if present, according to the separate instructions.
8. Check other functions according to separate instructions.
9. Check that all the transport safety devices have been removed.

DISMANTLING/REASSEMBLY

It is possible to dismantle the eQ unit. Dismantling should be carried out without damaging individual components. Reassembling the unit is associated with compromised functionality and leakage issues. Dismantling and reassembling of the eQ unit results in invalidation of any liability regarding functionality and leakage class from FläktGroup side.

Factory staff will discover if a unit has been dismantled and reassembled.

If possible, notify the factory if dismantling of the unit is planned. Facilitating and quality ensuring measures can be taken.

SOUND TRANSMISSION

If a unit is located by a wall, low-frequency sound generated in the unit may create vibrations in the wall, even though the noise level in the fan room is acceptable.

The unit should preferably be installed by the wall in the fan room that does not border on a soundsensitive space. If such a wall is lacking, install the unit 400–500 mm from the wall.

Duct lead-throughs must be carefully designed so that there will not be any rigid contact between the duct and the wall. The insulation around the ducting must also be carefully fitted so as not to transmit sound to adjoining spaces.

It is advisable to interconnect the ducts by means of flexible connections if they are arranged through sensitive spaces.

Sound may correspondingly be transmitted through the floor if the composition/mass and rigidity of the floor is inadequate.

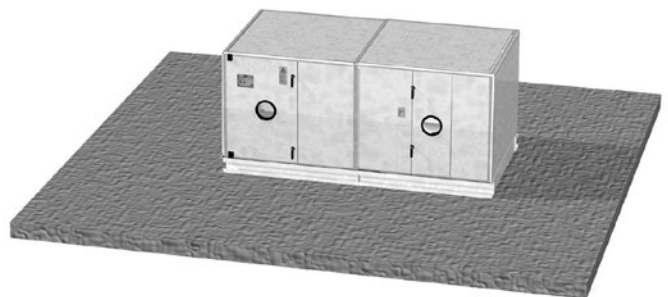

The mass must at least be equivalent to the recommendation specified in VVS AMA 98 (Part RA, Section QE) (General Material and Workmanship Specifications for Building Services Installations in Sweden), i.e. the mass of a floor having a surface that is 4 times the surface of the air handling unit must be at least 5 times the mass of the vibrationisolated object (i.e. the air handling unit above and supported on anti-vibration mountings).

If the floor has a light structure, its mass and rigidity can be improved by laying a heavy-duty insulation mat on the floor beneath the entire air handling unit. The whole bottom of the unit must then rest on the mat (and plate, if fitted).

GENERAL INSTRUCTIONS

LIFTING AND TRANSPORT

The weight of each multi-function block is specified on the rating plate.

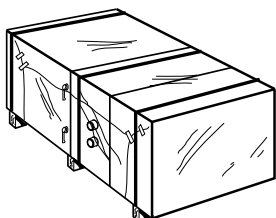

Each block is provided with packaging.

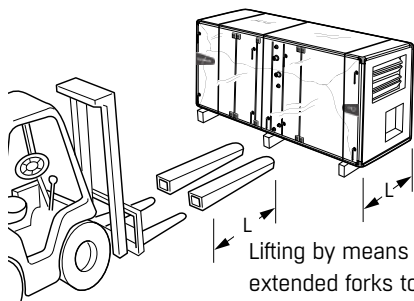

Lifting by means of a forklift truck with extended forks to avoid damaging to the bottom of the air handling unit.

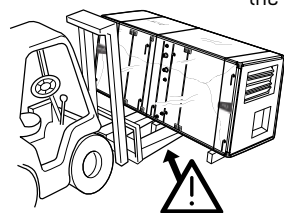

NB!

The centre of gravity may be offset from the centre of the air handling unit.

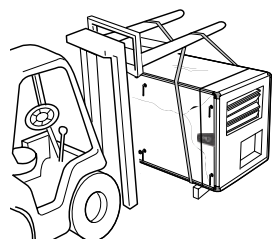

Using a forklift truck with the forks over the unit.
Unit sizes 005-090.

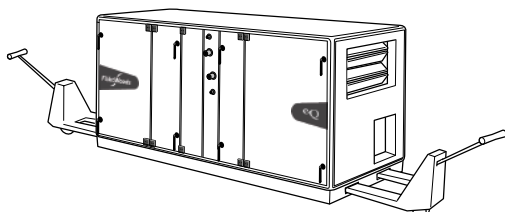

Larger and heavier units can be raised by using a hand-operated form loader on both short sides to avoid damage to the underside of the unit.

LIFTING A UNIT PROVIDED WITH LIFTING DEVICE EQAZ-02

Do not walk under a suspended load.

No persons shall be allowed to be beneath a suspended air handling unit.

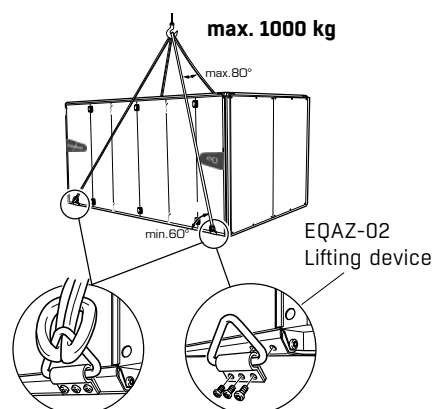

Important!

The EQAZ-02 lifting device must always be secured with three screws in the longitudinal bottom frame member.
Under no circumstances shall the lifting lug be secured to the upper corners.



NOTE!

If there is a base frame, the screws that secure the base frame with the unit must always be checked before lifting to ensure they are intact.
The lifting of the unit must under no circumstances be carried out with a wooden rail mounted on the base frame.

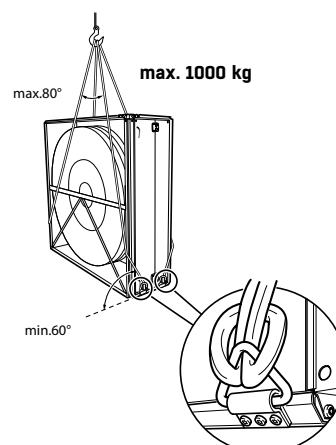

GENERAL INSTRUCTIONS

LIFTING A UNIT PROVIDED WITH A BASE FRAME EQAZ-04

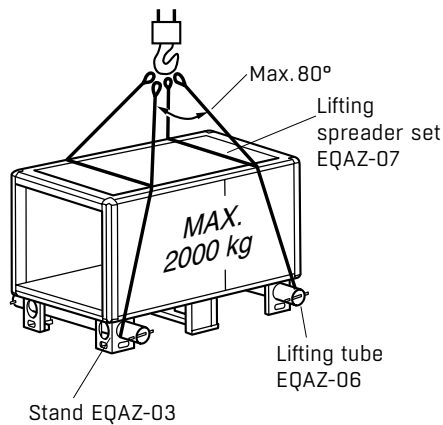
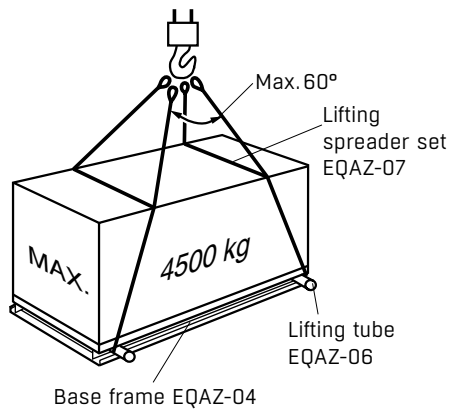
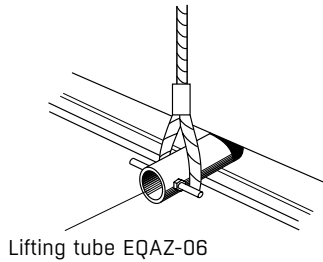

LIFTING AND TRANSPORT, OUTDOOR VERSION

The weight of each multi-function block is specified on the rating plate. Use EQAZ-06 lifting tubes and EQAZ-07 lifting spreader set to lift the unit/blocks on to the previously prepared foundation.

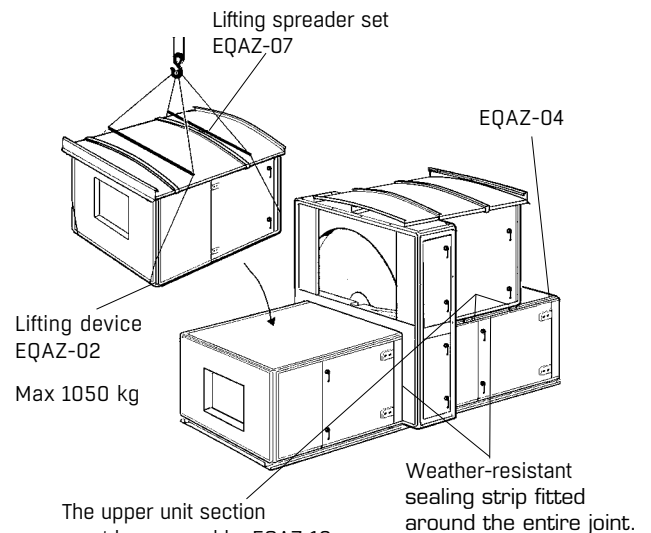
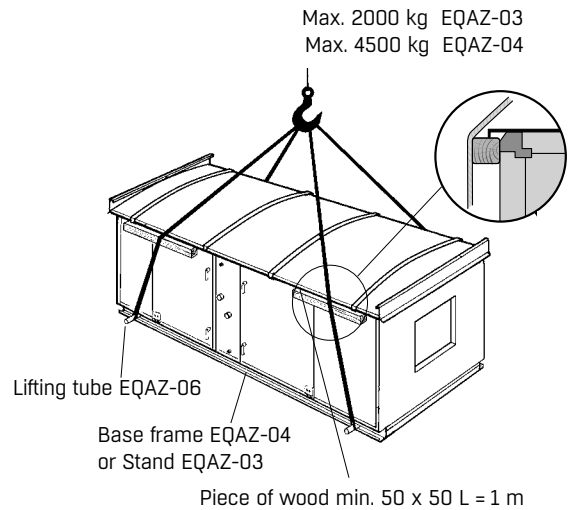

The upper unit section must be secured by EQAZ-16 joining piece set.
Max. distance between joining pieces: 1,5 m (see next page).



Note!

- Lift tubes are only suited for air handling units supplied from FläktGroup.
- The lift tubes must only be used for the specific unit that they have been ordered to.
- The lift tubes are adapted for each unit size.
- The lift tubes are intended to lift the unit once.
- If there is a base frame, the screws that secure the base frame with the unit must always be checked before lifting to ensure they are intact.

GENERAL INSTRUCTIONS

EQAZ-04 BASE FRAME, UNIT SIZES 005-090

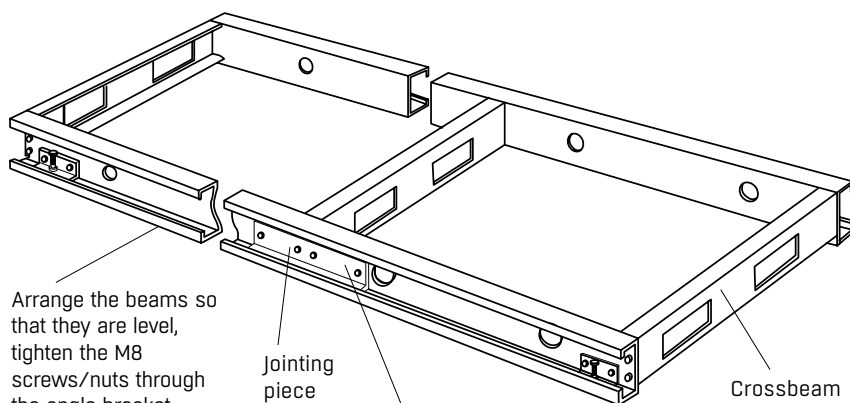

Arrange the beams so that they are level, tighten the M8 screws/nuts through the angle bracket, beam and cross beam to 28 Nm.

Jointing piece

Crossbeam

Drill 4 $\varnothing 7,3$ mm holes using the $\varnothing 6,3$ pilot holes provided and fit M8 Taptie self-tapping screws as safety screws.

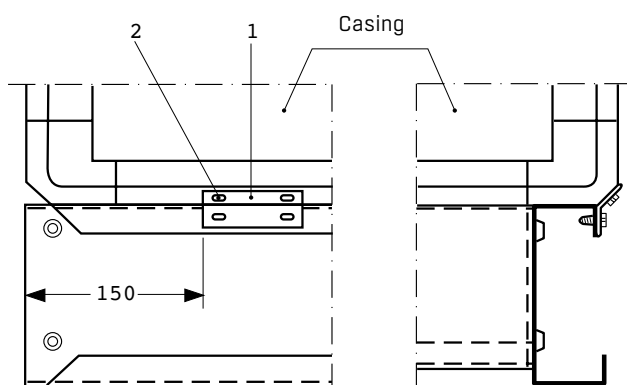

ASSEMBLY OF THE EQAZ-04 IN SEPARATELY DELIVERED VERSION

The base frame can be supplied either in assembled or unassembled condition. Assemble the base frame as shown, using one cross-beam at every beam joint and, if required, several cross-beams evenly distributed along the base frame.

TO FIT (SECURE) THE UNIT TO THE BASE FRAME

Fit one angle bracket (1), at each end of the base frame. Fit the remaining angle brackets spacing them evenly along the beams. Secure them with self-tapping screws (2).

GENERAL INSTRUCTIONS

MOUNTING ON THE FLOOR

The floor on which the unit is mounted must be level, to ensure its problem-free function. Carefully check the floor to ensure that distortion and problems in opening and closing the doors are not built into the unit.

Base frame EQAZ-04 can be supplied with adjustable feet EQAZ-05 for individual height adjustment. These are available for unit sizes 005-090. Non-adjustable feet are available for larger sizes. It is important to ensure that the unit is positioned horizontally.

Space for a water trap (e.g. EQAZ-08) must be provided for air handling units which contain functional components with a drainage facility.

Lateral and longitudinal position adjustment is most easily performed with a roller crowbar or similar.

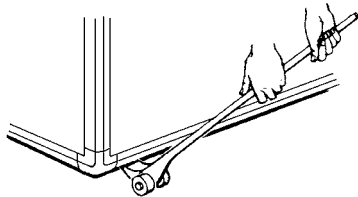

Multi-function block without base frame.

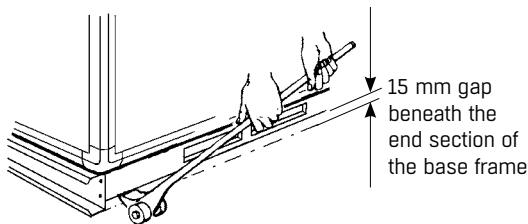

Multi-function block on base frame EQAZ-04, unit sizes 005-090.

MOUNTING ON THE FOUNDATION, OUTDOOR VERSION, UNIT SIZES 009-090

Secure the air handling unit base frame to the foundation by means of bolts. It is important to make sure that the unit is level.

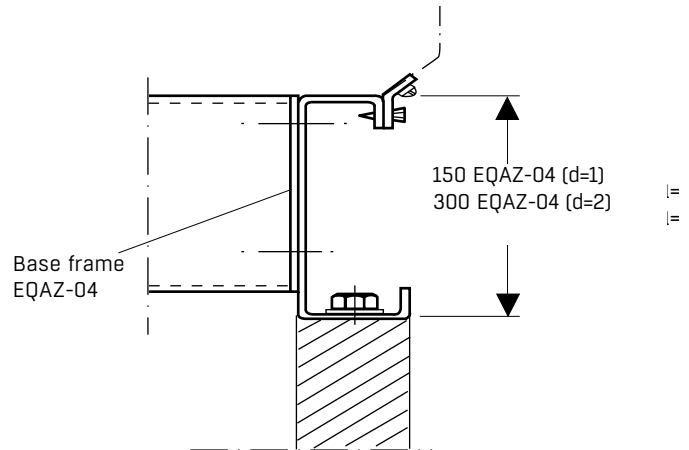

Size	A	Size	A
005, 009	774	032	1774
008, 014, 020	1074	041, 054, 068	1974
011	1174	047, 050, 063, 079	2274
018, 027, 036	1374	072, 090	2574
023, 045, 056	1674		

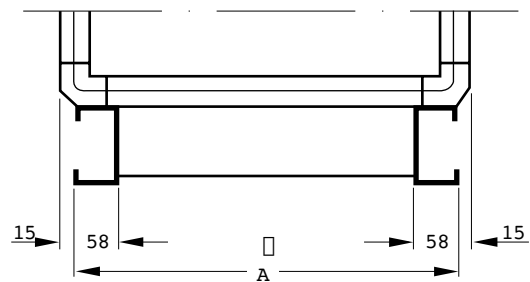

Important!

The EQAZ-16-30-1 or EQAZ-16-50-1 angle brackets must always be secured to the air handling unit in the version for outdoor installation.

GENERAL INSTRUCTIONS

JOINTING OF AIR HANDLING UNIT BLOCKS

1



NOTE!

Install the sealing strip on one side prior to assembly.

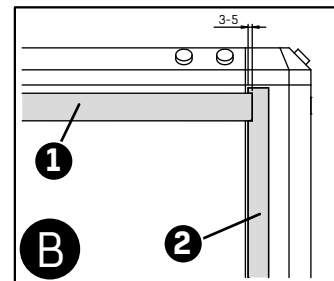
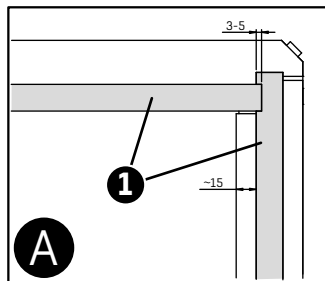
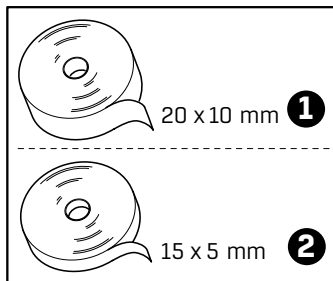

EQGA

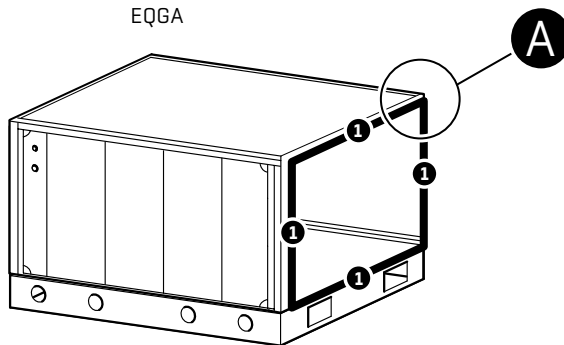

EQGB

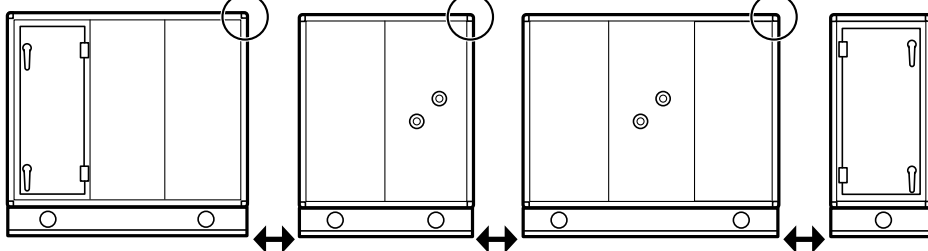
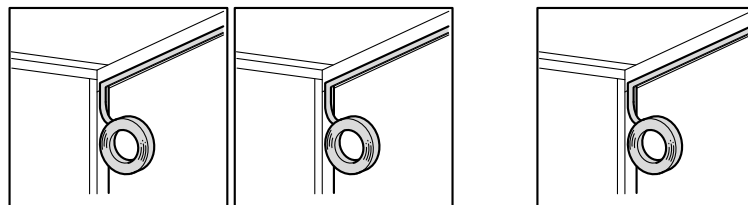
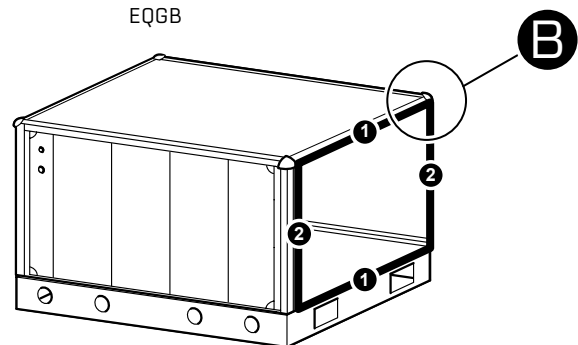

GENERAL INSTRUCTIONS

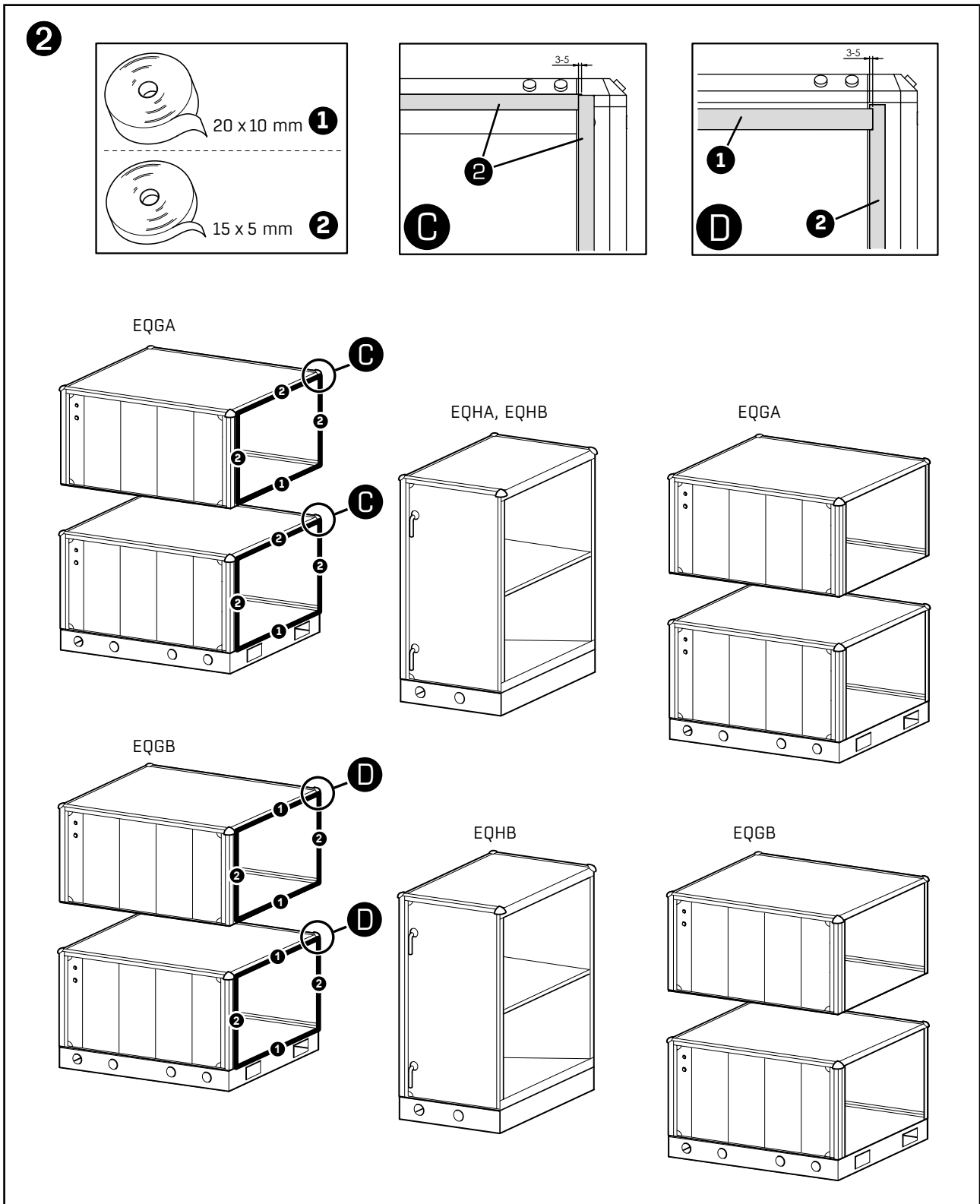

GENERAL INSTRUCTIONS

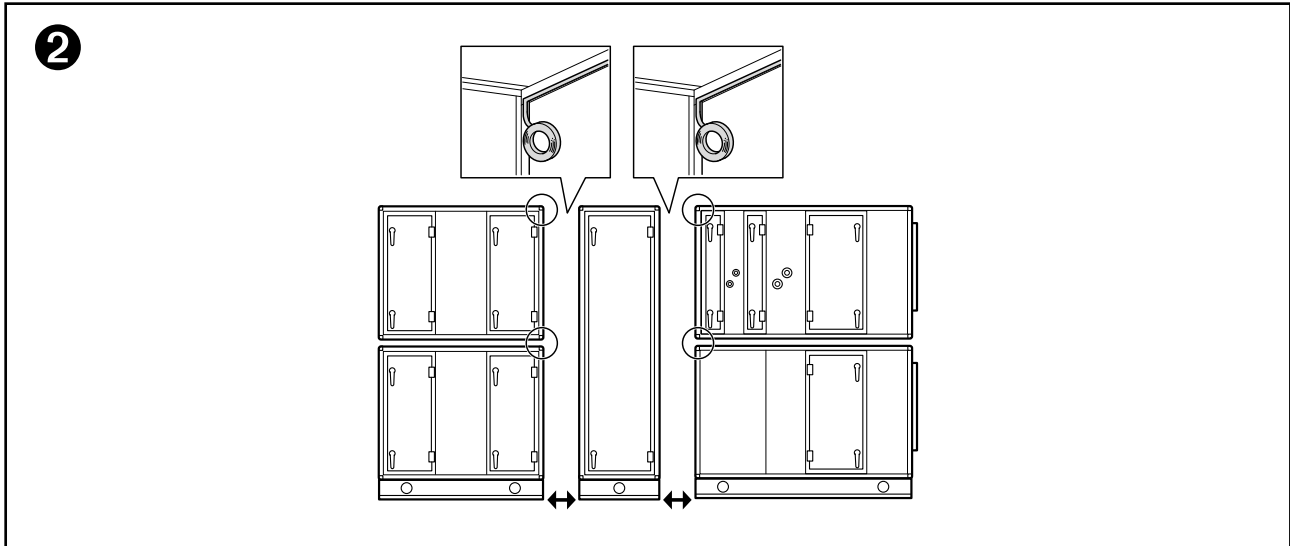

3

Externally

NOTE: If the unit is ordered with lifting devices they are mounted in the factory. After usage they should be removed and discarded. The docking devices should be mounted at the same location, using the same holes for the screws.

All docking brackets must be joined with the enclosed screws and nuts, or bolt screws and nuts.

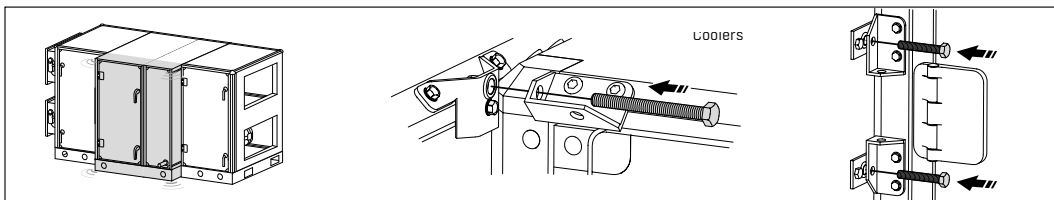
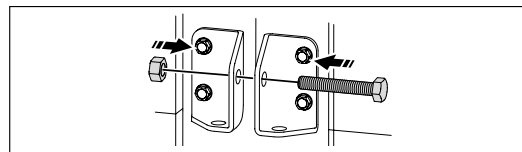
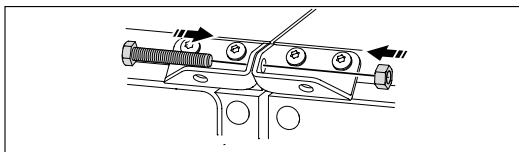
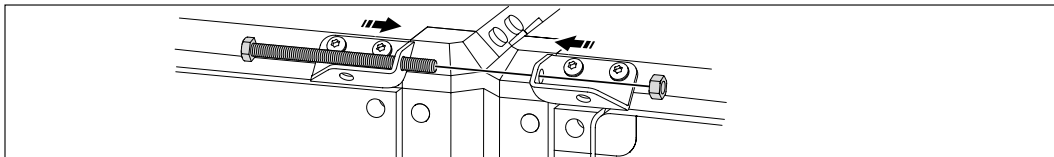

Internally

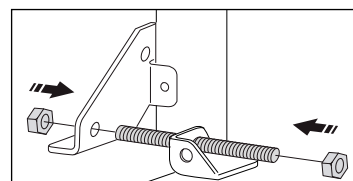
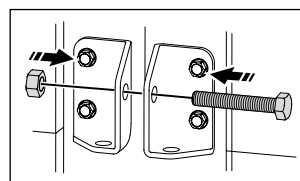
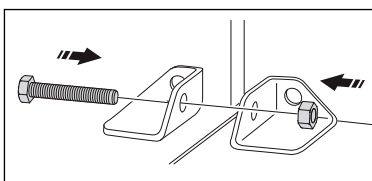

GENERAL INSTRUCTIONS

3 Rear side

Tip: In cases where accessibility is limited on the rear side of the unit, a threaded bar can be used as docking.

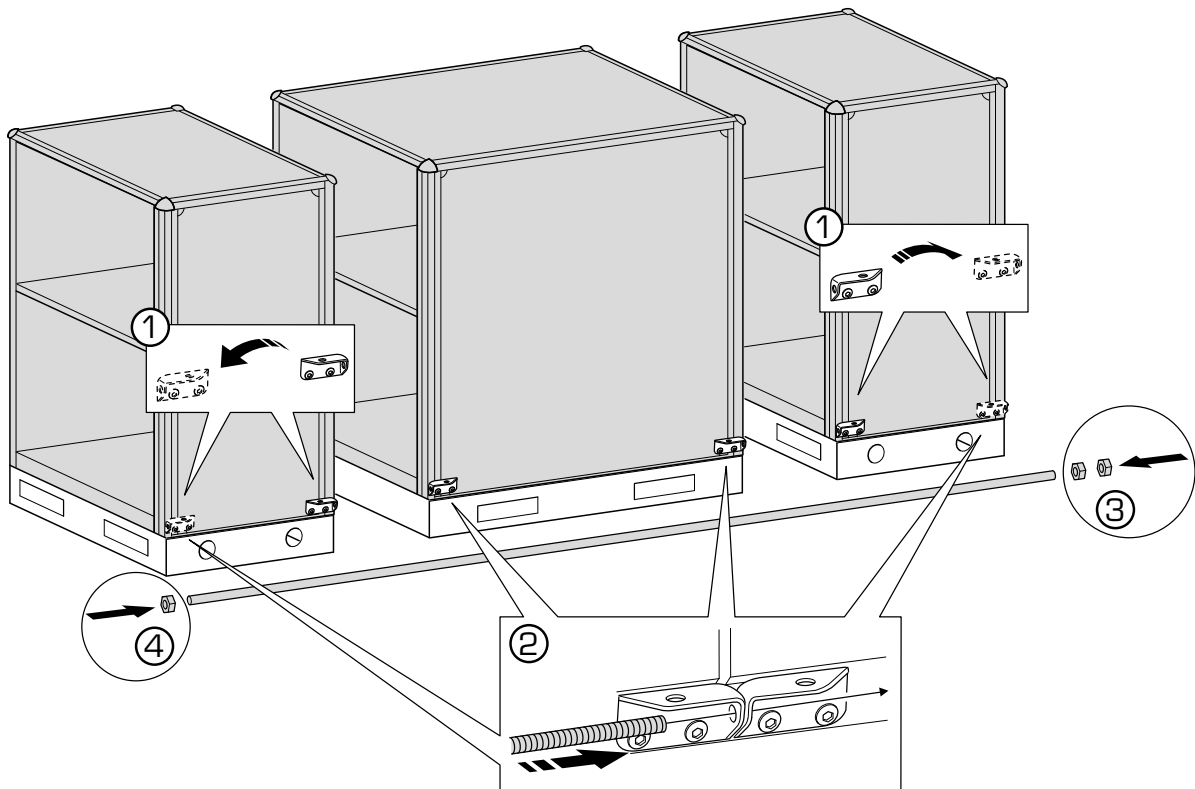

GENERAL INSTRUCTIONS

SUSPENDED MOUNTING FROM THE CEILING

Place the unit on a frame constructed on-site. See the Examples below. Suspend the frame from pendant hangers.

Larger units must be equipped with EQAZ-29 floor grating to enable service personnel to enter.

The frame must also be executed so that so that the base panels have either transverse or longitudinal support rails on the underside.



Important!

A frame of the kind shown in figure below permits easy adjustment of the hangers.

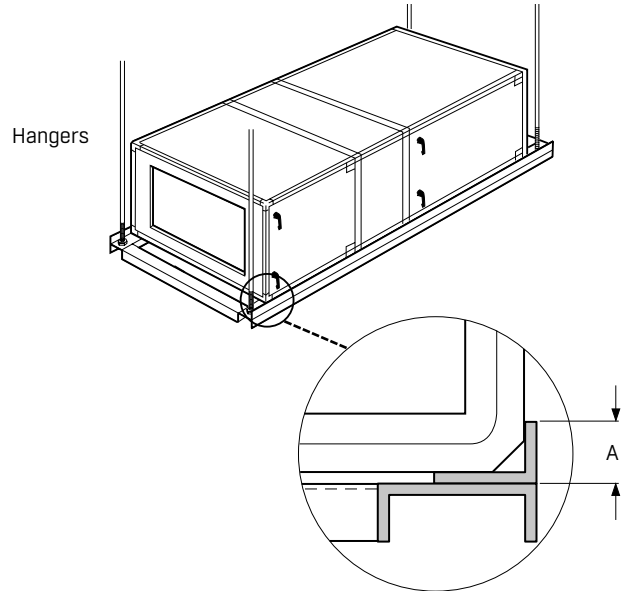
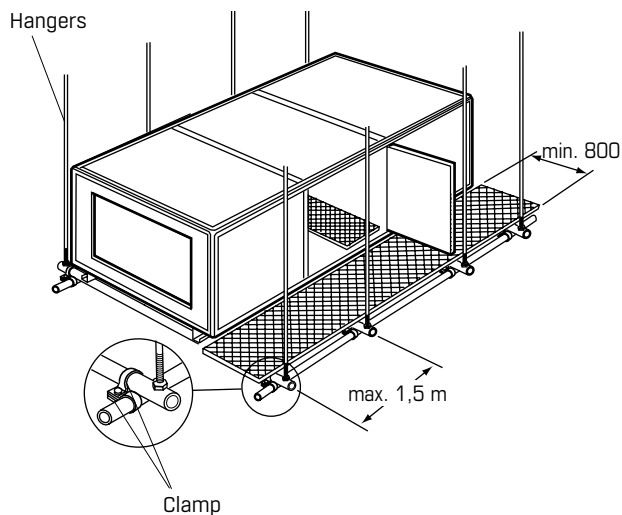

Retaining flange A – max. 35 mm along the inspection side unite sizes 005-090.

Cut and remove the edge "A" at the hinge locations to unite sizes 005-090.

Retaining flange A – max. 75 mm along the inspection side unite sizes 081-216.



N.B.!

If the air handling unit is equipped with a EQWZ-02 drainage trough, the edge of the retaining flange (A) can only be at the casing corner posts.

HEAVY DUTY INSTALLATION

Suitable installation for sizes 036-090.

Example 1

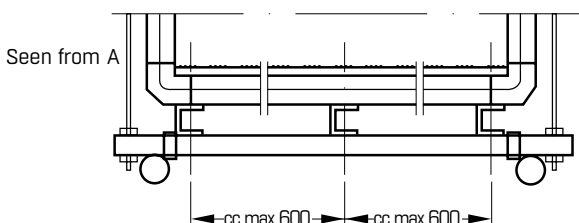
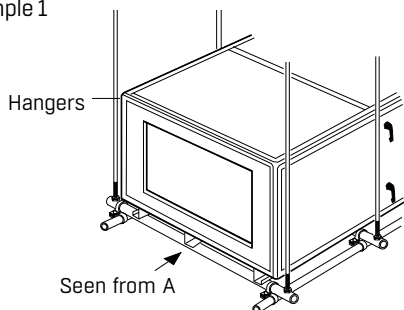

HEAVY DUTY INSTALLATION

Suitable installation for sizes 036-090.

Example 2

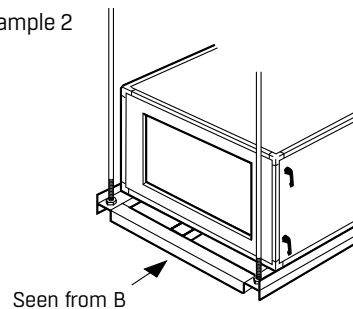

GENERAL INSTRUCTIONS

SUSPENDED INSTALLATION, HYGIENIC VERSION, UNIT SIZES 005-090

Place the unit on a stand made on site as shown in the examples below. Suspend the stand from hangers.

Larger units must be equipped with EQAZ-29 floor grating to enable service personnel to enter.

The frame must also be executed so that so that the base panels have either transverse or longitudinal support rails on the underside.



N.B.!

If the unit is equipped with a EQWZ-02 drainage trough, there are retaining flanges (A) only at the casing corner pieces.

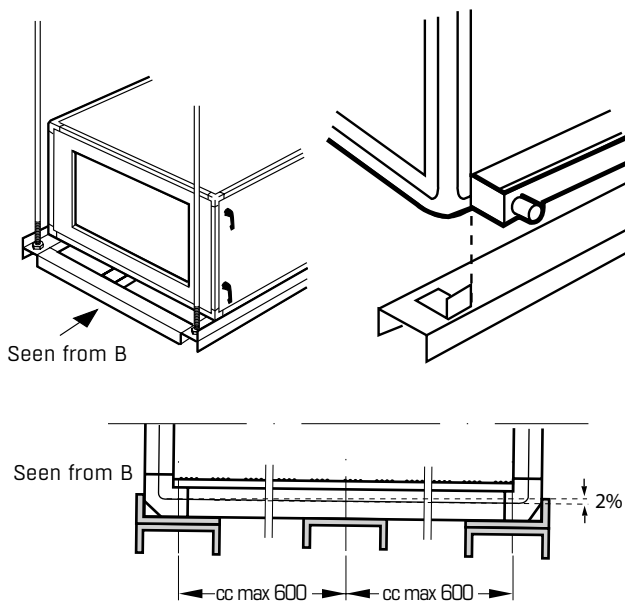

GENERAL INSTRUCTIONS

UNITS STACKED ON TOP OF ONE ANOTHER (ONLY FOR EQGA, EQGB)

Units of the same width can be stacked on top of one another. Up to two size 005-032 units can be stacked on top of one another.

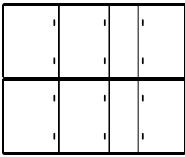

EQGA, EQGB
Double deck
Unit sizes 005-032

If the units are of different widths, arrange the inspection sides so that they are in the same plane. Place an angle profile under the rear frame profile of the top unit (length = length of lower unit) and fit a bar for height compensation under the front frame section.

Fit EQAZ-16-01-1 sealing strip around the opening of the empty section before fitting the upper unit.

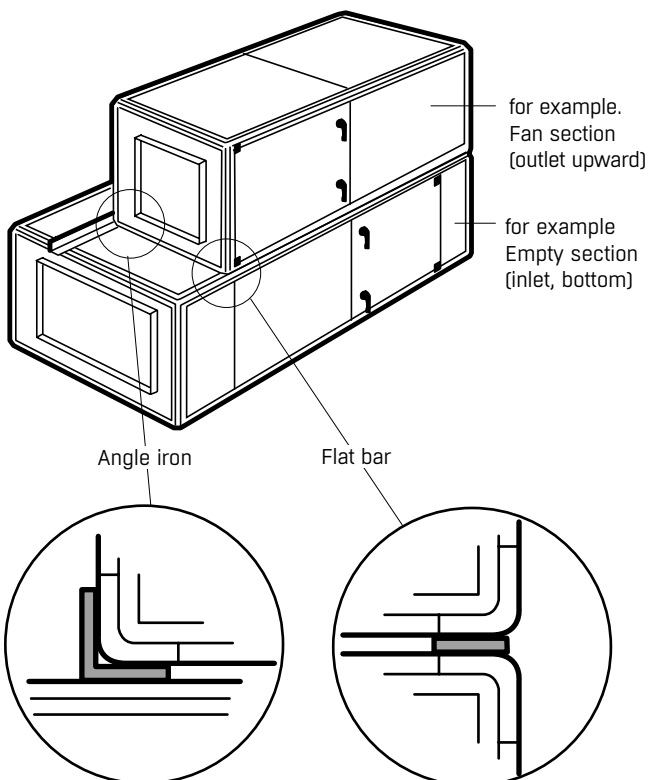

The EQAZ-16-30-1 (sizes 005-090), EQAZ-16-50-1 (unit sizes 108-216) jointing piece set is used for securing the upper units to the lower as shown.

The set consists of 6 angle brackets. Use the angle bracket as a template and secure it to the frame section with self-tapping screws. (Spacing, max. 1.5 m.)



Important!

The EQAZ-16-30-1 or EQAZ-16-50-1 angle brackets must always be secured to the air handling unit in the version for outdoor installation.

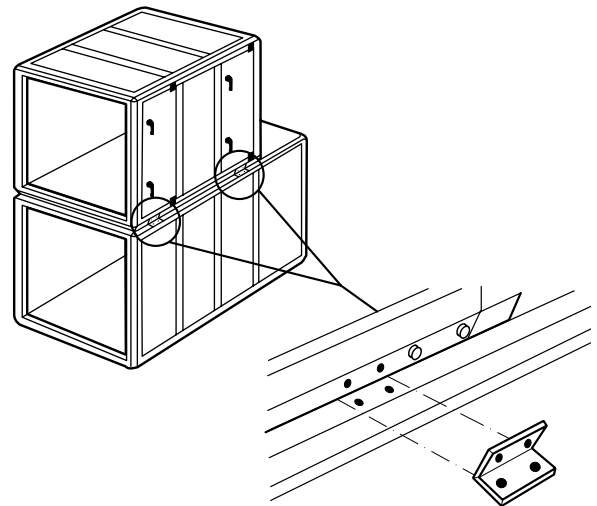

GENERAL INSTRUCTIONS

SUPPORTING FRAME FOR OVERHANGING UNIT PARTS

Unit configurations where the upper block overhang the lower block needs to be supported and secured.

The accessory EQAZ-11 (Supporting frame), is used for this purpose as shown in the picture below.

In cases where EQAZ-11 hasn't been ordered, it is the responsibility of the installer to properly support and secure the unit.

FläktGroup does not take responsibility for any injuries or damages that may occur when other equipment than EQAZ-11 is used to support overhanging block parts.

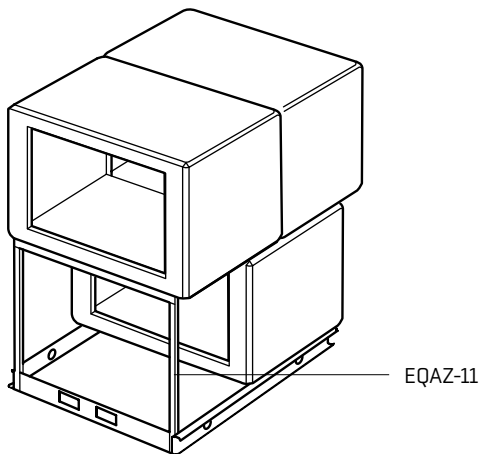

Warning!

The unit should be secured in a professional manner.

Contact FläktGroup for consultation if needed. Overhanging and unsecured block parts can lead to personal injuries and material damages.

VERTICAL MOUNTING. THE UNIT MUST BE ORDERED FOR VERTICAL INSTALLATION. UNIT SIZES 005-009 (SINGLE DECK CASING), 005-008 (DOUBLE DECK CASING)

The following supporting surface is required for a vertical arrangement:

Flat floor or frame made of angle steel, for example 50 x 50 x 5 with outer dimensions adapted to the outer dimensions A x B of the air handling unit.



N.B!

Vertical installation can be employed only for unit sizes 005-009 in single deck casing and for unit sizes 005-008 double deck casing.



Important!

The stand must not be designed in such a manner that the inlet or outlet or the inspection doors are obstructed. Anchoring the unit to a wall can appropriately be done with clamps or anchor brackets, such as perforated strips.

MOUNTING ON A WALL STAND

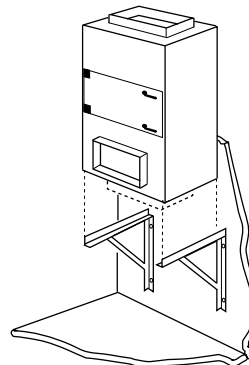

MOUNTING ON A FLOOR STAND

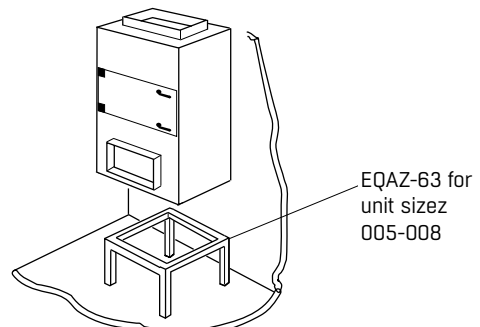

GENERAL INSTRUCTIONS

INSTALLATION OF THE JOINTS, ONLY APPLIES FOR OUTDOOR UNITS

The EQBZ-01 roof is fitted to each individual unit at the factory as shown.

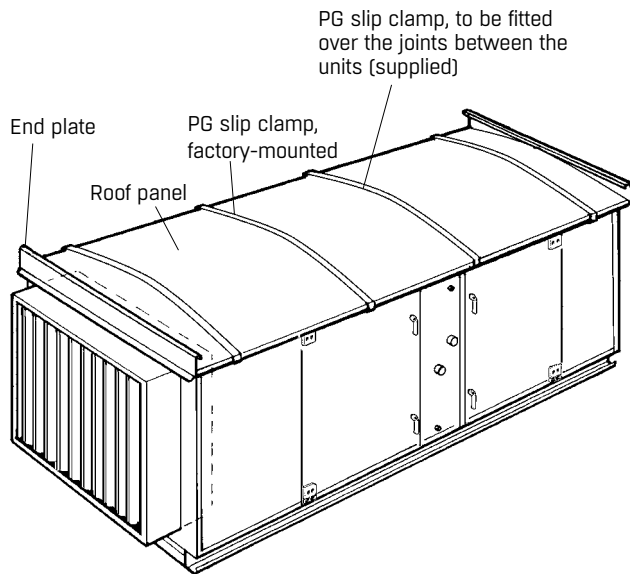

Roof joint to be fitted on site when multi-function blocks are delivered.

PG slip clamp, sizes 009-090 or cover trim, sizes 108-216, to be fitted over the joints between the units (supplied).

Center the PG slip clamp so that its right-hand end extends equally as much as its left-hand end from the edge of the roof. Then bend the clip clamp ends over the edge of the roof.

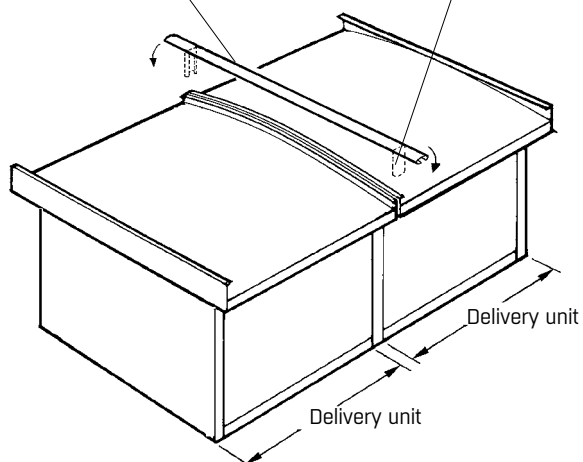

On size 108-216 units, place the cover trim on the joint where the folded edges of the roof sections meet and secure it by applying light hammer blows to "snap" it on.

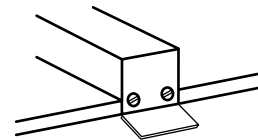
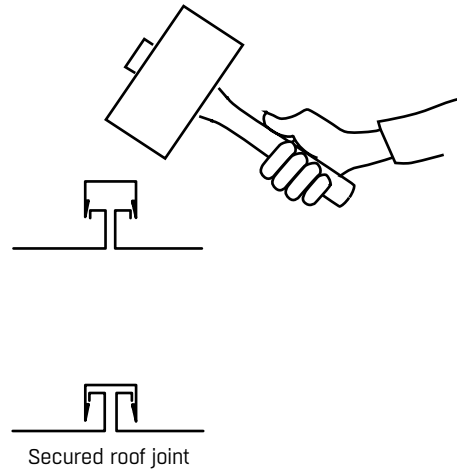

Secure the end pieces using self-threading screws.

GENERAL INSTRUCTIONS

TO DISMANTLE THE HANDLES WITH/WITHOUT LOCK

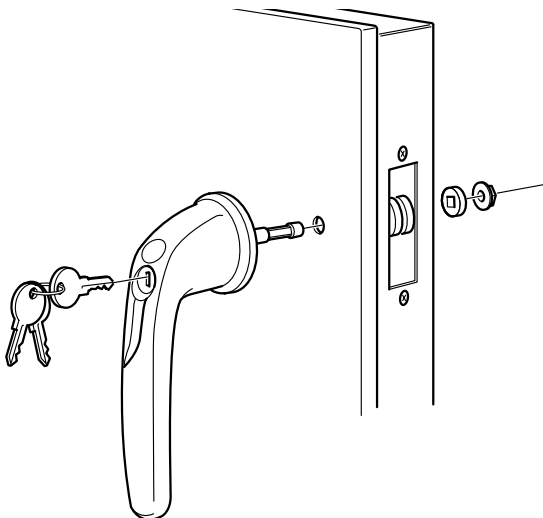
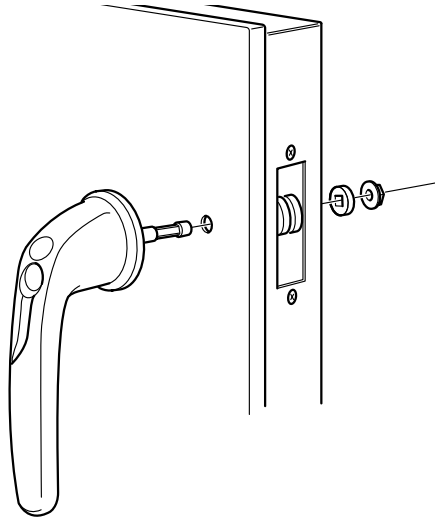

LOCK WITHOUT HANDLE

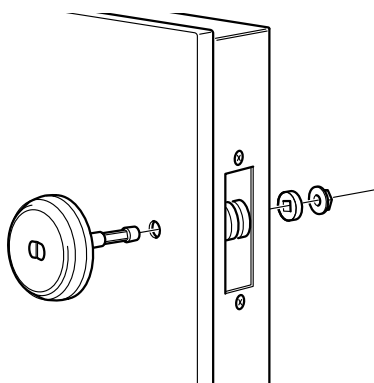

TO ADJUST THE HINGES

Back off the screws and shift the hinge in the appropriate direction. Tighten the screws and check that the door opens and closes easily.

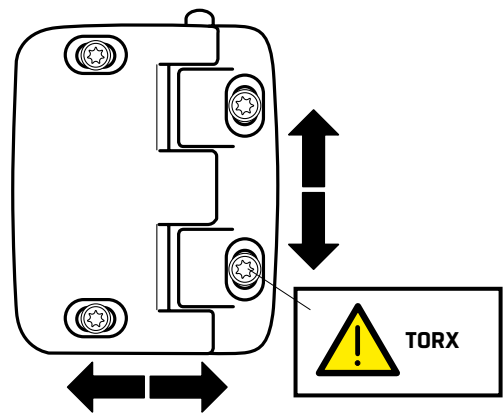

GENERAL INSTRUCTIONS

CONNECTION TO THE DUCTING

The external functional sections such as coils, sound absorbers, etc. can be connected directly to the outlet of the plenum fan.

INSTALLATION PRINCIPLE – DUCT FITTED TO FAN OUTLET

All connections should be fitted edge-to-edge with the back plate of the fan.

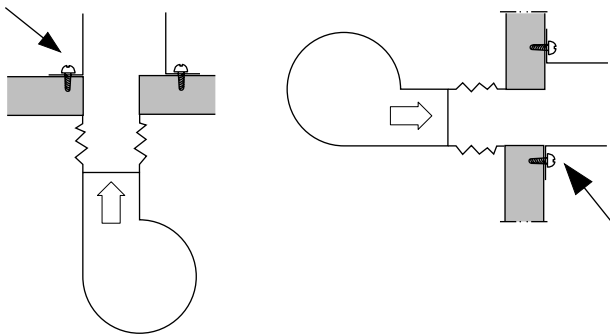

Important!

The weight of the air duct system with components must not load the unit.

MAINTENANCE

Regular maintenance of this air handling unit can be carried out by the company normally responsible for maintaining the property.

REPLACEMENT OF DOOR SEAL

The door seal is available as a spare part and must be replaced, if necessary, to ensure that the unit is airtight.

SPARE PARTS

Spare parts and accessories for this unit can be ordered from our nearest sales office. If spare parts of a different make are used, FläktWoods declines guarantee liability for malfunctions that may result. The guarantee is valid for genuine components only and provided that the air handling unit has not been disassembled.

The order should also state the product code. The code can be found on a separate data panel located on the functional component concerned.

INSPECTION INTERVALS

A number of service schedule forms are included in separate instruction 8646, and these should be filled in by the person entrusted with the maintenance of the unit.

The service chart includes the service and inspection operations to be performed on functional components that may be part of an air handling unit. The unit contains one or more of these functional components. Any components that are not relevant may be deleted from the service chart.

The chart shall be dated and signed each time servicing is carried out. The length of the service interval is estimated at 2000 operating hours over a 12-month period and for an installation providing a normal comfort level.

In environments with a high level of dust in the supply air or exhaust air, inspection of the air handling unit shall be performed at more frequent intervals.